	Όν. Πελάτη:.....	Σφραγίδα Αντιπροσώπου	Tube PRISMA	Σημειώσεις:
	Ημερομηνία:.....		Insert : <input type="checkbox"/>
	Υπογραφή:.....		Μοτέρ απο κάτω: <input type="checkbox"/>
				Στη σειρά Tube (ελευθέρως κανοδόχου), αφήνουμε 10-12mm ανοχή δεξιά-αριστερά-επάνω για να σφραγιστεί με ειδ. κορδόνι.

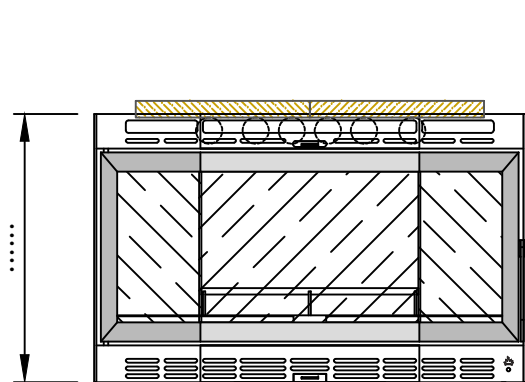

Πρόσωση

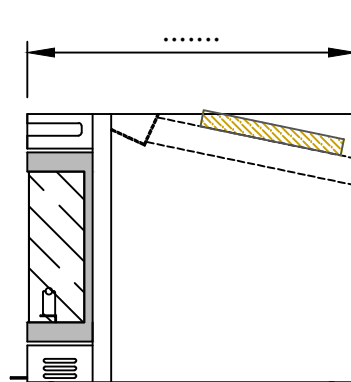

Πλάγια Όψη 1

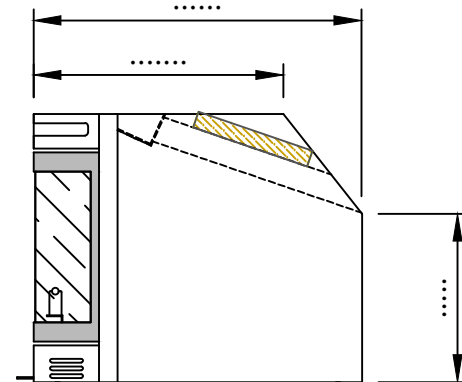

Πλάγια Όψη 2

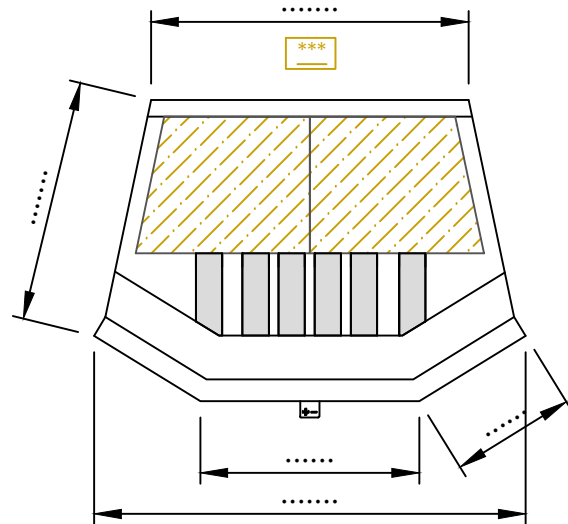

Κάτοψη 1

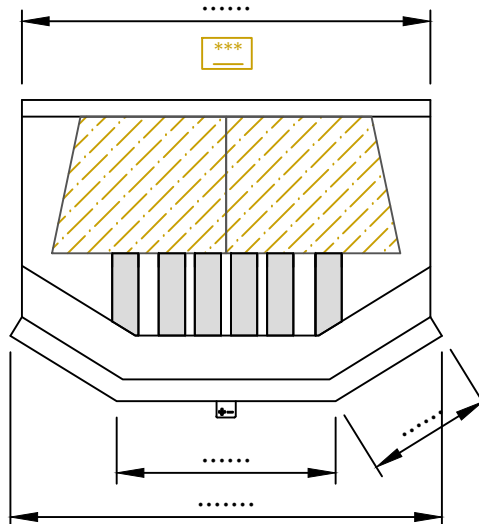

Κάτοψη 2

Επιλογή moter:

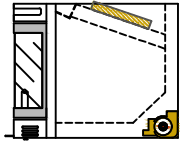

insert (350m³/h)

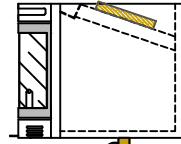

Μοτέρ απο κάτω (350m³/h)

******* Στη σειρά Insert, η συγκεκριμένη διάσταση πρέπει να είναι μεγαλύτερη ή ίση με 450mm.





Customer:

Date:

Signature:

Partner stamp

Tube PRISMA

Insert :

Fan Under :

Notes:

In Tube series (no-chimney), we set a 10-12mm tolerance (L-R-U side). Then, we seal with special cord.

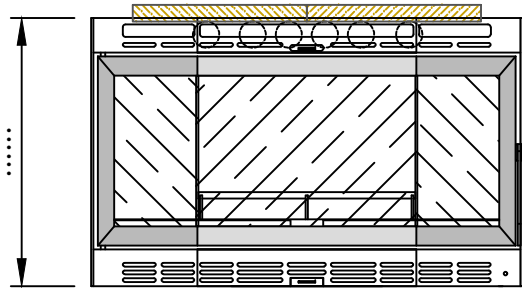

Front view

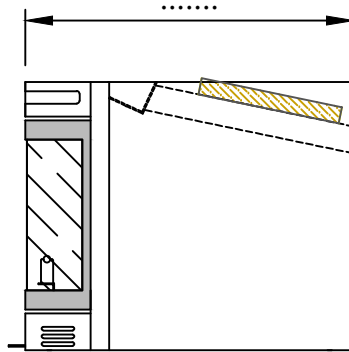

Side view_1

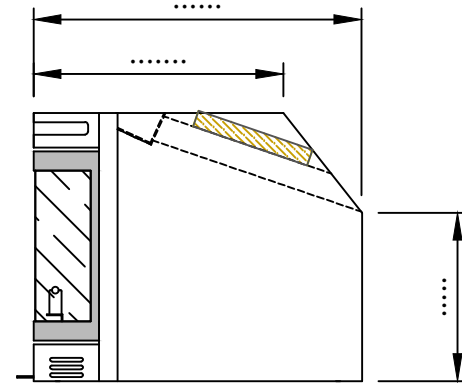

Side view_2

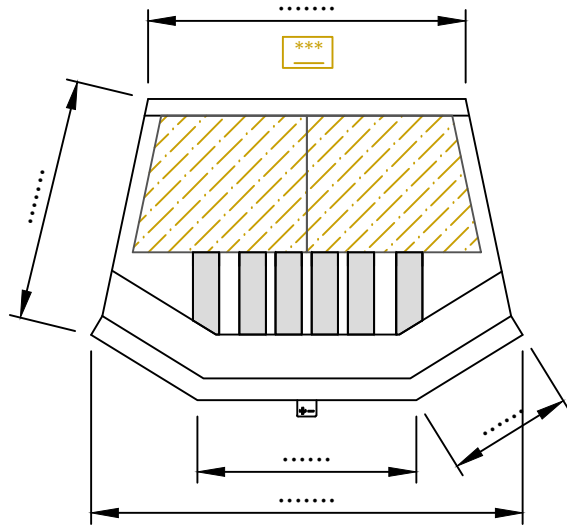

Top view 1

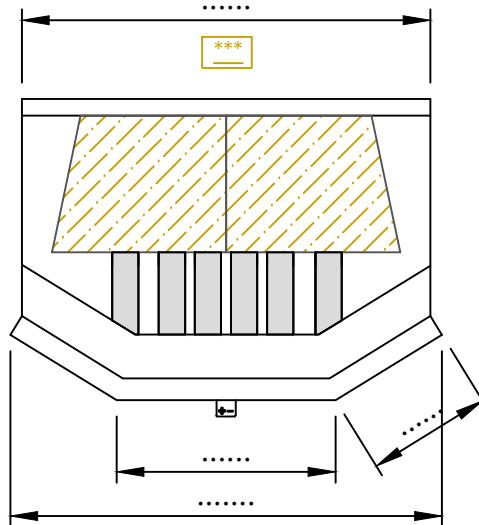

Top view 2

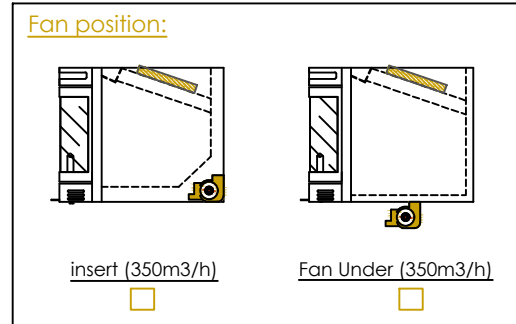

******* In Insert series, the indicated dimension must be bigger or equal to 450mm.

